

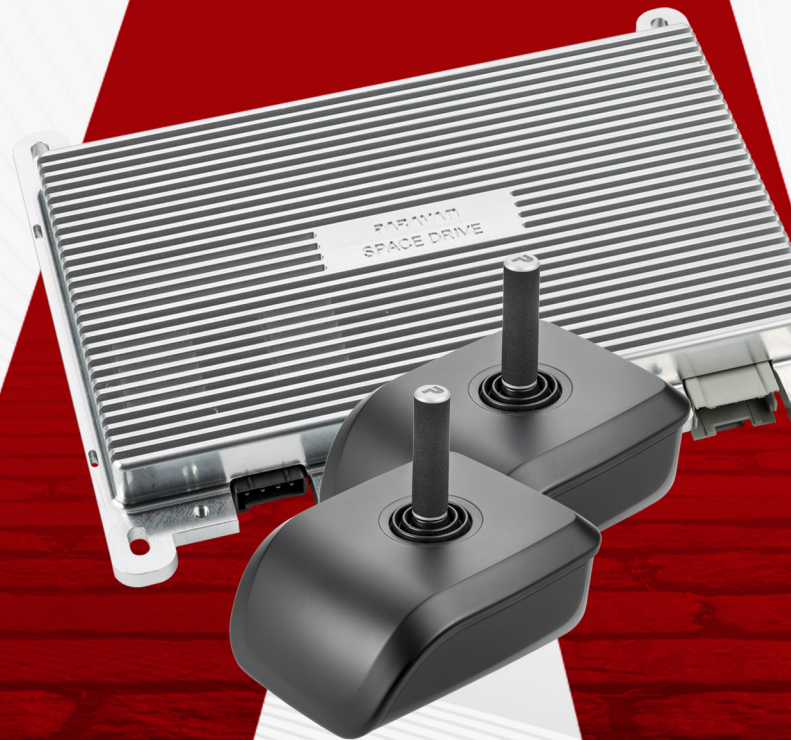

PARAVAN SPACE DRIVE SYSTEM

User Manual
PRIMARY FUNCTIONS



 **EN/US** v3.0

Valid for the following models:

Publisher and copyright:

Date of issue:

Document number:

Paravan Space Drive II System

PARAVAN GmbH

1.11.2020

Benutzer_SD_Primaer_V3_EN-US

Dear Customer,

Thank you for choosing our PARAVAN SPACE DRIVE II driving system. You will find all the important information and suggestions you need for your PARAVAN SPACE DRIVE II driving system in this User's Manual. Please carefully read the information on the pages to follow in order to make sure that your PARAVAN SPACE DRIVE II driving system will give you many years of problem-free service. Keep this User's Manual in a handy place in your vehicle for later reference. Our user manual contains answers to questions relating to the equipment, operation and care of the PARAVAN SPACE DRIVE II driving system. If you should have any questions or suggestions about the PARAVAN SPACE DRIVE II driving system, please do not hesitate to contact us.

We wish you a pleasant ride!

Your PARAVAN team

Table of contents

General

| | | |
|-----------|---|-----------|
| 1. | Details of publisher | 10 |
| 1.1 | Your manufacturer | 10 |
| 1.1.1 | Copyright | 11 |
| 2. | On this User's Manual | 12 |
| 2.1 | General issues..... | 12 |
| 2.1.1 | Driving direction information | 12 |
| 2.1.2 | Technical status of this documentation..... | 13 |
| 2.1.3 | Trademark | 14 |
| 2.2 | Disclaimer | 15 |
| 2.2.1 | Guarantee | 16 |
| 2.2.2 | Technical alterations | 17 |
| 2.3 | Target groups | 19 |
| 2.4 | Explanation of symbols..... | 20 |
| 2.4.1 | Structure of safety notices..... | 21 |
| 3. | Safety note..... | 22 |
| 3.1 | General safety notes..... | 22 |
| 4. | Functional description | 28 |
| 4.1 | Manufacturing standard..... | 28 |
| 4.1.1 | General issues..... | 28 |
| 4.1.2 | Equipment characteristics of the driving system | 29 |
| 4.1.3 | Standards and directives applied | 30 |
| 4.2 | Appropriate usage | 31 |
| 4.2.1 | Use of a vehicle with a driving system | 32 |

| | | |
|-------|--------------------------------|----|
| 4.3 | Approvals, certifications..... | 33 |
| 4.3.1 | ECE regulations..... | 33 |
| 4.3.2 | Battery used..... | 34 |
| 4.3.3 | EMV test..... | 35 |

Information

| | | |
|-----------|---|-----------|
| 5. | Details relating to the product..... | 36 |
| 5.1 | The serial number..... | 36 |
| 6. | Overview of the SPACE DRIVE II driving system..... | 37 |
| 6.1 | Definition of terms for parts and their positions..... | 37 |
| 7. | Operating and control elements..... | 39 |
| 7.1 | General information regarding operating elements..... | 39 |
| 7.1.1 | Control and monitoring of the driving system..... | 40 |
| 7.1.2 | Overview of operating elements..... | 41 |
| 7.2 | Overview of operating elements..... | 42 |
| 7.2.1 | Individual modules/elements..... | 42 |
| 7.2.2 | Possible combinations of the individual modules..... | 43 |
| 7.3 | Orthopaedic extensions..... | 44 |
| 7.4 | Overview of operating elements..... | 45 |
| 7.4.1 | Check control..... | 45 |
| 7.4.2 | Accelerator/brake lever and two-way joystick..... | 46 |
| 7.5 | General information regarding operating elements..... | 47 |
| 7.6 | Function of the operating elements..... | 48 |
| 7.6.1 | Steering servo-motor..... | 48 |
| 7.6.2 | Accelerator and brake servo-motor..... | 49 |

Prepare

| | | |
|-----------|---|-----------|
| 8. | Delivery of the vehicle | 50 |
| 8.1 | Receiving your new/altered vehicle | 50 |
| 8.2 | The vehicle is delivered to you as follows | 50 |
| 8.2.1 | Settings on the vehicle | 51 |
| 9. | Preparation of the vehicle for driving..... | 52 |
| 9.1 | Driving with the PARAVAN SPACE DRIVE driving system | 52 |
| 9.1.1 | Put the locking pin in the correct position..... | 54 |
| 9.1.2 | Align the steering and the steering servo-motor | 57 |
| 9.2 | Driving without the PARAVAN SPACE DRIVE driving system..... | 60 |
| 9.3 | Insurance, personal liability insurance | 62 |
| 9.4 | Functional checking before driving..... | 63 |

Operate

| | | |
|------------|---|-----------|
| 10. | Operating the PARAVAN driving system | 64 |
| 10.1 | Starting the driving system, sequence of steps..... | 64 |
| 10.1.1 | Before starting the motor | 64 |
| 10.1.2 | After starting the motor | 66 |
| 10.2 | Operating the accelerator and brake function | 68 |
| 10.2.1 | Accelerator/brake joystick (2-way) | 68 |
| 10.2.2 | Accelerator/brake lever (2-way)..... | 69 |
| 10.3 | Operating the steering function | 70 |

| | | |
|-------------|--|-----------|
| 10.3.1 | Mini-steering-wheel | 70 |
| 10.3.2 | Steering joystick (2-way) | 71 |
| 10.3.3 | Rotational steering unit | 72 |
| 10.4 | Operating the accelerator/brake function and the steering function | 73 |
| 10.4.1 | Accelerator/brake and steering joystick (4-way) | 73 |
| 11. | Operating the Check Control..... | 74 |
| 11.1 | Navigation in the menu structure | 74 |
| 11.1.1 | Menu structure of the Check Control | 75 |
| 12. | Customer menu..... | 76 |
| 12.1 | Battery voltages | 76 |
| 12.2 | Fine-calibration of the steering | 77 |
| 12.3 | Software version | 78 |
| 12.4 | Maintenance intervals | 79 |
| 12.5 | Date and clock | 80 |
| 12.6 | Button illumination, color | 81 |
| 12.7 | Button illumination, day | 82 |
| 12.8 | Button illumination night | 83 |
| 13. | Loading and transporting your vehicle | 84 |
| Help | | |
| 14. | Care and maintenance..... | 85 |
| 14.1 | Cleaning and care | 87 |
| 15. | Disposal and environmental protection..... | 88 |
| 15.1 | Packaging materials | 89 |
| 15.2 | Re-commissioning | 90 |
| 15.3 | Notes on transferring the vehicle..... | 91 |

| | | |
|------------|---|-----------|
| 16. | Correcting failures..... | 92 |
| 16.1 | Initial steps, fault search | 92 |
| 16.2 | Fault message..... | 93 |
| 17. | Emergency mode | 94 |
| 17.1 | Accident..... | 95 |
| 18. | Your contact to the PARAVAN customer service | 96 |
| 18.1 | Hotline | 96 |

Technology

| | | |
|------------|--|------------|
| 19. | Electrical system..... | 97 |
| 19.1 | Notes on the power supply | 97 |
| 19.1.1 | Starting the vehicle with external power | 98 |
| 19.2 | Charge the batteries | 99 |
| 19.3 | Notes on maintenance charge..... | 100 |
| 19.3.1 | Maintenance charge..... | 101 |
| 20. | Technical equipment..... | 102 |
| 20.1 | Technical data..... | 102 |
| 20.2 | Replacement parts..... | 103 |
| 21. | Systems and technical documentation | 104 |
| 21.1 | Handling the sealed backup battery | 104 |
| 21.2 | Certification for lithium battery..... | 105 |
| 21.2.1 | Copy of the certificate | 105 |

| | | |
|----------|------------------------------------|----|
| Fig. 1: | QR Code..... | 10 |
| Fig. 2: | Direction of travel..... | 12 |
| Fig. 3: | SPACE DRIVE Logo..... | 14 |
| Fig. 4: | Safety note..... | 21 |
| Fig. 5: | Accelerator/brake servo-motor..... | 29 |
| Fig. 6: | Steering servo-motor..... | 29 |
| Fig. 7: | ECE marking..... | 33 |
| Fig. 2: | Serial number..... | 36 |
| Fig. 3: | Overview..... | 37 |
| Fig. 4: | Components..... | 38 |
| Fig. 5: | PARAVAN main module..... | 40 |
| Fig. 6: | Check control..... | 45 |
| Fig. 7: | Accelerator/brake lever..... | 46 |
| Fig. 8: | Two-way joystick..... | 46 |
| Fig. 9: | Accelerator/brake servo-motor..... | 47 |
| Fig. 10: | Steering servo-motor..... | 47 |
| Fig. 11: | Steering servo-motor..... | 48 |
| Fig. 4: | System switch..... | 52 |
| Fig. 5: | Steering not switched on..... | 53 |
| Fig. 6: | Check Control display..... | 53 |
| Fig. 7: | Locking pin position..... | 54 |
| Fig. 8: | Locking pin..... | 55 |
| Fig. 9: | Locking pin..... | 56 |
| Fig. 10: | Steering not switched on..... | 57 |
| Fig. 11: | Middle position, move..... | 57 |
| Fig. 12: | Latch steering..... | 58 |
| Fig. 13: | Start motor..... | 58 |
| Fig. 14: | Start screen..... | 59 |

| | | |
|----------|-------------------------------------|----|
| Fig. 15: | Fuses, mechanical | 59 |
| Fig. 16: | System switch..... | 60 |
| Fig. 17: | Locking pin | 60 |
| Fig. 18: | Unlocking bolt | 61 |
| Fig. 19: | Locking pin | 61 |
| Fig. 20: | Fasten seat belt, logo | 63 |
| Fig. 11: | Sequence of steps | 64 |
| Fig. 12: | Sequence of steps | 65 |
| Fig. 13: | Sequence of steps | 66 |
| Fig. 14: | Sequence of steps | 67 |
| Fig. 15: | Accelerator/brake joystick | 68 |
| Fig. 16: | Accelerator/brake lever | 69 |
| Fig. 17: | Mini-steering-wheel | 70 |
| Fig. 18: | Steering joystick..... | 71 |
| Fig. 19: | Rotational steering unit | 72 |
| Fig. 20: | 4-way joystick..... | 73 |
| Fig. 21: | Operating panel Check Control | 74 |
| Fig. 22: | Menu structure..... | 75 |
| Fig. 23: | Sequence of steps | 76 |
| Fig. 24: | Fine calibration..... | 77 |
| Fig. 25: | Software version | 78 |
| Fig. 26: | Maintenance intervals | 79 |
| Fig. 27: | Date / time..... | 80 |
| Fig. 28: | Button illumination..... | 81 |
| Fig. 29: | Button illumination..... | 82 |
| Fig. 30: | Button illumination..... | 83 |
| Fig. 16: | Recycling | 89 |
| Fig. 17: | Critical fault!..... | 93 |

| | | |
|----------|--|-----|
| Fig. 17: | Backup battery | 100 |
| Fig. 18: | Button for external charging | 101 |
| Fig. 19: | Certification for lithium battery..... | 105 |

1. Details of publisher

1.1 Your manufacturer

General

Information

Prepare

Operate

Help

Technology



Fig. 1: QR Code

PARAVAN GmbH
Main office / HQ/ Production Plant

PARAVAN[®]

MOBILITY FOR LIFE

Paravanstraße 5-10, D-72539 Pfronstetten-Aichelau

- > Phone: +49 (0) 73 88 / 99 95-91
- > Fax: +49 (0) 73 88 / 99 95-999
- > Email: info@paravan.com
- > Internet: www.paravan.com
- > Managing director: Roland Arnold



Many mobile phones and PDAs contain an integrated camera and software that will allow you to interpret QR codes so that you can read our contact information directly into the address book of your mobile phone or PDA.

1.1.1 Copyright

This documentation and all its constituent sections are protected by copyright. The rights established in this way, in particular those related to translation, reprinting, representation, extraction of illustrations and tables, broadcast, microfilming or any other means of reproduction and saving in data processing systems, even if only excerpts are used, are reserved.

Any reproduction of this work or of any parts of this work, even in exceptional cases, is only permitted within the limits set by the terms of the copyright act of the Federal Republic of Germany dated 9 September 1965 in its currently valid version. It is generally subject to charges. Any infringements will be subject to the penal clauses of the aforementioned copyright law.

> Copyright © PARAVAN GmbH 2020. All rights reserved!

2. On this User's Manual

2.1 General issues

2.1.1 Driving direction information

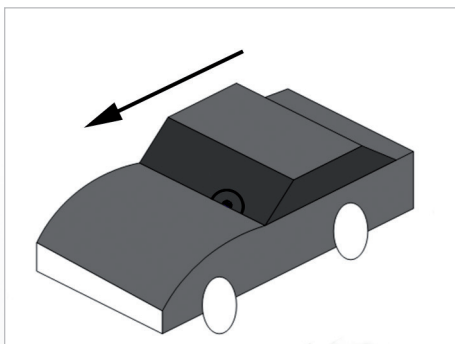

Fig. 2: Direction of travel

This User's Manual does not include maintenance and repair instructions, that could be used by the owner to perform maintenance and repair work on his own or to support such work. It includes information concerning the operation during the entire life cycle, from initial transport (delivery) to disposal (decommissioning) of the PARAVAN SPACE DRIVE II driving system. The product's most important features are listed and described below. All product features mentioned for different versions and functions may be combined with each other and may deviate from the standard version.



This User's Manual is an integral part of the PARAVAN SPACE DRIVE II driving system and must always be retained in the vehicle to ensure that you have fast access to important information. All page and directional indications made are always given from the point of view of the operator looking in a driving direction.

2.1.2 Technical status of this documentation



All details on technical data and/or specifications, illustrations and information in this User's Manual correspond to the final version in June 2014.



The User's Manual for the PARAVAN SPACE DRIVE II driving system was compiled in German and may be translated into other languages. In the event of any discrepancies, the German version will be legally binding.

2.1.3 Trademark



Fig. 3: SPACE DRIVE Logo



The product names PARAVAN® and SPACE DRIVE® are trademarks entered into the register according to trademark and patent law. The brand SPACE DRIVE® designates the individual components and the complete uniform electronic, digital driving system of the company PARAVAN GmbH. This trademark guarantees the quality of the driving system. Only PARAVAN GmbH is entitled to use the designations PARAVAN® and SPACE DRIVE®.

Registered and protected trademarks are:

- > PARAVAN®
- > SPACE DRIVE®

2.2 *Disclaimer*

Operation of the PARAVAN SPACE DRIVE II without errors and faults can only be guaranteed when the information provided in this User's manual is considered and implemented. PARAVAN GmbH does not accept any liability or give any guarantee regarding damage or malfunctions that result during operation when the instructions in this User's Manual are not adhered to or when the PARAVAN SPACE DRIVE II is altered.

In order to ensure fault-free operation of your PARAVAN SPACE DRIVE II, please observe the maintenance instructions and intervals.



See "Maintenance instructions"

2.2.1 Guarantee

Guarantee cover is exclusively defined by the respective PARAVAN warranty conditions.

Explicitly excluded from warranty claims is any damage resulting from:

- Wear and tear
- Inappropriate operation or use
- Incorrect/Irregular maintenance
- Incorrect/Irregular care



See your personal "Guarantee card"

2.2.2 Technical alterations

Any modifications made to the safety equipment and technical changes to the PARAVAN SPACE DRIVE II driving system, however small, are strictly prohibited. All alterations must be executed by PARAVAN GmbH.

PARAVAN GmbH reserves the right to make technical alterations and improvements to the product in the interests of our customers and as a result of advancing technology.



Warranty and guarantee claims become void after any modification of the PARAVAN SPACE DRIVE II driving system that was not approved by PARAVAN GmbH. Furthermore, dangerous malfunction cannot be ruled out.



WARNING

Risk of personal injury when operating the vehicle with a driving system that does not correspond to the original or delivery state.

Physical damage to the vehicle or the driving system due to non-authorized or incorrectly installed components.

- > Do not make any technical changes to your SPACE DRIVE system.
- > Only operate your driving system in its original or delivery state.
- > Use only original or authorized replacement parts.
- > Check the operating state of the vehicle and the SPACE DRIVE driving system before each drive.

2.3 Target groups

The operator (vehicle driver) must fulfill the following requirements and have or acquire knowledge regarding the following issues before operating a vehicle with a PARAVAN SPACE DRIVE II driving system:

- > Have a valid driving license in the respective country of operation.
- > Know the contents of the User's Manual in order to operate a vehicle with a PARAVAN SPACE DRIVE II driving system safely and to drive it.
- > Know the safety and operating instructions in the User's Manual of the PARAVAN SPACE DRIVE II driving system and the vehicle in order to recognize potential risks or dangerous situations and to prevent harm to him and his environment.



Only trained and instructed persons may operate a vehicle with a PARAVAN SPACE DRIVE II driving system to ensure their own safety.



You, the operator (driver) of the vehicle should insist on sufficiently detailed instruction when the vehicle with the PARAVAN SPACE DRIVE II driving system is handed over to you. Contact us where necessary.



See Section "1.1 Your manufacturer"



See Section "8 Vehicle handover"

2.4 Explanation of symbols

You will come across the following symbols and warning signs while reading the User's Manual.



The "Caution, Danger" logo

Calls your attention to danger points. The preventative measures contained in the associated text must always be followed. This symbol always appears with an associated signal word which indicates the level of danger.

- > **Danger!** - Imminent danger to life and limb (irreversible).
- > **Warning** - Possible danger to life and limb (irreversible).
- > **Caution** - Possible danger to life and limb (reversible).
- > **Caution** - Possible material damage to the vehicle.



Additional information to the user, e.g. to make the use of the driving system easier and/or to prevent material damage to the vehicle or the driving system.



This symbol refers the user to another section or more detailed documentation, e.g. to annexes to this User's Manual.

2.4.1 Structure of safety notices

You can find the following information in the safety notes:

- > Warning or hazard symbol ①.
- > Type and source of hazard ②.
- > Signal word ③.
- > Consequences of occurrence ④.
- > Preventative action ⑤.

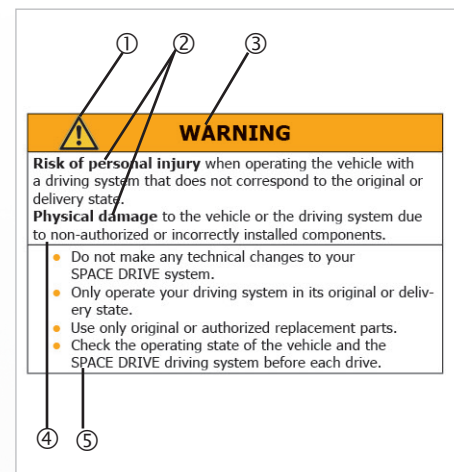

Fig. 4: Safety note

3. Safety note

3.1 General safety notes

You must under all circumstances observe the following safety notes for your own safety, for that of people in your vicinity and to protect the environment.



DANGER!

Mortal danger for persons operating the vehicle with a SPACE DRIVE driving system that does not correspond to the original or delivery state.

Mortal danger for persons who lose control of their vehicle due to unapproved alterations.

Damage to the operating elements of the SPACE DRIVE driving system due to non-authorized or incorrectly installed orthopaedic extensions.

- > Do not make technical changes to the operating elements of the driving system.
- > Only operate the SPACE DRIVE driving system in its original or delivery state.
- > Only use original or authorized orthopaedic extensions.



DANGER!

Mortal danger for persons operating the vehicle with a SPACE DRIVE driving system when the safety pin is not inserted in the steering servo-motor.

Mortal danger for persons who have not been instructed and therefore lose control of the vehicle.

- > No driving when the safety pin has not been inserted into the steering servo-motor.
- > Check the safety pin in the steering servo-motor for correct position, particularly after changing from handicapped driving mode to normal driving or vice versa.



DANGER!

Mortal danger for persons driving a vehicle with a SPACE DRIVE system when the vehicle and the drive system are not subject to regular inspection.

Mortal danger for all persons who lose control of their vehicle due to inappropriately performed maintenance, inspection or repair work.

Damage to the vehicle and the SPACE DRIVE system when the inspection and repair work is not performed by authorized service technicians or maintenance personnel.

- > Perform maintenance and inspection work according to the maintenance plan.
- > Maintenance, inspection or repair work on the driving system may only be performed by certified service technicians or maintenance personnel.
- > Maintenance and inspection intervals must always be adhered to.



WARNING

Risk of injury for persons operating the vehicle with a SPACE DRIVE driving system that does not correspond to the original or delivery state.

Physical damage to the vehicle or the SPACE DRIVE system due to non-authorized or incorrectly installed components.

- > Do not make any technical changes to your SPACE DRIVE system.
- > Only operate the SPACE DRIVE driving system in its original or delivery state.
- > Use only original or authorized replacement parts.
- > Check the operating state of the vehicle and the SPACE DRIVE driving system before each drive.



WARNING

Risk of injury for persons who operate the vehicle in emergency mode after failure of power support systems e.g. steering pump, servo-pump.

Damage to the vehicle in emergency mode due to failure of power support systems, e.g. steering pump, servo-pump.

- > Increased steering and braking effort will be necessary. Drive proactively and with particular care.
- > Restore the appropriate operating state of the vehicle and the driving system.
- > Use only original or authorized replacement parts.
- > Visit a workshop or service station and have the fault removed.



WARNING

Risk of injury for persons operating the vehicle with a SPACE DRIVE driving system that does not correspond to the original or delivery state.

Physical damage to the vehicle or the SPACE DRIVE system due to non-authorized or incorrectly installed components.

- > Do not make any technical changes to your driving system.
- > Only operate the SPACE DRIVE driving system in its original or delivery state.
- > Use only original or authorized replacement parts.
- > Check the operating state of the vehicle and the SPACE DRIVE driving system before each drive.

4. **Functional description**

4.1 **Manufacturing standard**

4.1.1 General issues

The PARAVAN SPACE DRIVE II driving system is a modular control system that controls the primary systems accelerator, brake and steering by multi-channel digital communication. The operator (driver) of the vehicle has the option of entering appropriate sensor specifications into the primary systems or the input devices that will then be executed by the controllers (PARAVAN main module) or the actuators (accelerator and brake servo-motors).

This makes it possible to provide the PARAVAN main module with driving and diagnostic vehicle data, e.g. speed or rotation speed signal.

Data exchange between the

- SPACE DRIVE II Check Control and the
- PARAVAN main module

is performed by using a High Speed CAN-BUS (Control Area Network).

The data transferred may consist of the following data groups:

- System state information, diagnostic or calibration data
- Illness-related parameters regarding the operator
- Error codes, language changes, customer service status, program updates

4.1.2 Equipment characteristics of the driving system

The PARAVAN SPACE DRIVE II driving system includes several servo-motors that move according to controller signals (PARAVAN main module):

- > A double-servo-motor for moving the accelerator and the brake pedal
- > A double-servo-motor for moving the steering wheel

The electronic steering and the electronic accelerator and brake functions were implemented in two autonomously operating controller units (PARAVAN main module) in order to ensure maximum safety.



Fig. 5: Accelerator/brake servo-motor

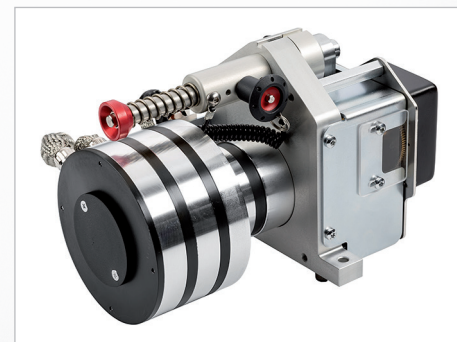

Fig. 6: Steering servo-motor

4.1.3 Standards and directives applied

The PARAVAN SPACE DRIVE II driving system only makes use of system components that are qualified according to the AEC (Automotive Electronics Council).



The AEC is an organization for standardising the qualification of electronic components in the automotive industry.

The PARAVAN SPACE DRIVE II driving system is produced and inspected (reliability test for integrated circuits) according to:

- > AEC Q100 for general electronic components
- > AEC Q101 for separate semi-conductor components
- > AEC Q200 for passive components

These standards ensure problem-free function and communication of the system components with the vehicle and between each other.

4.2 *Appropriate usage*

A vehicle with an active or passive PARAVAN SPACE DRIVE II driving system may only be used in public road traffic by persons who have a valid driving licence in the respective country of operation.



Vehicles with a PARAVAN SPACE DRIVE II driving system are exclusively intended for the application areas and use described in the Chapter "Use of the vehicle with driving system".



See Section "3 Notes on safety"



See Section "4.2.1 Use of a vehicle with driving system"

4.2.1 Use of a vehicle with a driving system

- unproblematic

- The vehicle and the SPACE DRIVE II driving system are in their original or delivery state.
- Participation in public road traffic according to the legal stipulations in the country of operation, e.g. Road Traffic Licensing Ordinance.
- Transport of persons in the vehicle according to the respective, approved number of persons.
- Transport of persons in the vehicle according to the respective, approved weight class.



See vehicle documentation or licensing documents for the vehicle

- problematic or prohibited

- Participation in motor sport events.
- Operation of the vehicle system under extreme climatic conditions, e.g. tropics, deserts or in polar regions.
- Driving or operating a vehicle under the influence of drugs, e.g. alcohol or medication.



See Section "2.2 Disclaimer"



See Section "3 Notes on safety"

4.3 Approvals, certifications

4.3.1 ECE regulations

The ECE regulations identify a catalog of internationally agreed upon, standardised technical regulations for powered vehicles as well as equipment or parts of powered vehicles.



The ECE is the "Economic Commission for Europe", an economic commission for Europe at the United Nations.

The contract parties (countries) accept the ECE regulations and permit the use and import of ECE type-tested vehicles and parts.

The PARAVAN SPACE DRIVE II driving system has the following ECE homologations:

- > ECE-R-79 Steering systems
- > ECE-R-13 Brakes – Part 1+2
- > ECE-R-10 Electromagnetic compatibility



See Section "21 Annexes and technical documentation"

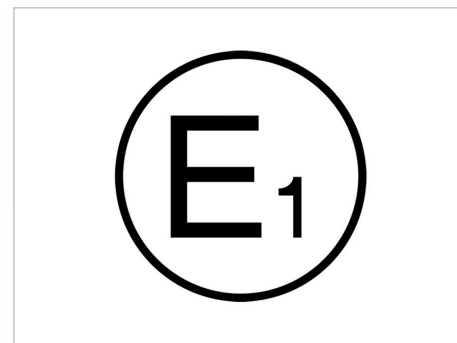

Fig. 7: ECE marking

4.3.2 Battery used

PARAVAN GmbH uses lithium-iron-phosphate batteries. They are a type of lithium-iron batteries. Lithium-iron-phosphate (LiFePO) is used as a cathodic material instead of the conventional cathodes. They are harmless as long as the batteries have no mechanical defects.

The maintenance-free lithium-ion batteries are tested according to:

- IEC 62133 (DIN EN 62133)
Batteries with alkaline or other acid-free electrolytes -
Safety requirements for portable, gas-tight batteries and battery units assembled from them for use in portable devices.

- UN 3480 and UN 3481
Test according to Test Manual Part III, 38.3, Rev. 5



See Section "21.2 Certification for Lithium Battery"

4.3.3 EMV test

The electromagnetic compatibility (EMC) defines the ability of a device to work reliably in an electromagnetic environment without unduly exposing this environment to electromagnetic effects.

The PARAVAN SPACE DRIVE II driving system has the following ECE homologation:

- > ECE-R-10 Rev. 04 Test Report P130468

5. Details relating to the product

5.1 The serial number



D082.01.00.016

Fig. 2: Serial number



The PARAVAN product is identified by an 11-digit serial number.

All individual system components can be identified by the serial number and allocated to the respective PARAVAN SPACE DRIVE II driving system.

It is very important to mention the serial number in all correspondence with PARAVAN GmbH to ensure that you receive technically correct advice.

This also ensures that you will receive an equivalent system component when an exchange is required due to maintenance or repair, e.g. after a specified maintenance interval.

It guarantees problem-free exchange of system components, as only components of an equivalent design and configuration are used or delivered.

6. Overview of the SPACE DRIVE II driving system

6.1 Definition of terms for parts and their positions



Fig. 3: Overview

The following terms for components and parts will be used in this User's Manual. The location of the PARAVAN SPACE DRIVE II driving system elements in the vehicle may vary, but the elements are located in direct reach of the operator (driver).

- > Accelerator/brake lever for acceleration/braking function ①
- > 2-way joystick ②
- > Mini-steering-wheel ③
- > 4-way joystick ④
- > Check control ⑤
- > Gear control ⑥
- > Rotary steering ⑦

The components in User's Manual may differ from the components installed in the vehicle, depending on the equipment version.

The following terms for components and parts will be used in this User's Manual. The location of the PARAVAN SPACE DRIVE II driving system elements in the vehicle may vary due to the availability of space in the vehicle.

- Steering servo-motor ①
- Accelerator/brake servo-motor ②
- Emergency switch / emergency gear control ③
- PARAVAN main module ④

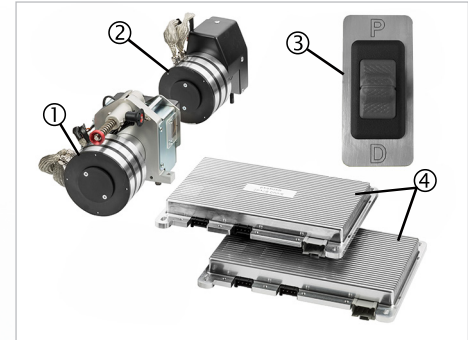

Fig. 4: Components

7. **Operating and control elements**

7.1 **General information regarding operating elements**

PARAVAN GmbH provides a broad offer of operating elements in the PARAVAN SPACE DRIVE II section. These operating elements are generally based on four controller types:

- > Accelerator/brake lever for acceleration/braking function
- > Two- or four-way joystick
- > Mini-steering-wheel
- > Handlebars



The driving system will have one or two of these operating elements, according to your individual needs.

The accelerator/brake function is controlled by an accelerator/brake lever; two-, four-way joystick.

The steering function can be handled by a two-, four-way joystick, a mini-steering-wheel or Rotary steering.

The combined functions of accelerator, brake and steering were implemented with the four-way joystick. The four-way joystick is the only operating element that can combine these functions.



See Section "7.4 Function of the operating elements"

7.1.1 Control and monitoring of the driving system

Input or driving commands by the operator are controlled and monitored by three potentiometers per axle, which are in continuous communication with the PARAVAN main module. Unintentional driving commands that might, for example, result from unevenness of the road, are prevented by supporting the operating elements with

- > thrust springs,
- > rotation dampers.

The PARAVAN SPACE DRIVE II driving system is programmed to use different parameters for different speeds. It is therefore possible to change the sensitivity of the operating elements as a function of speed. This implies:

- > A large movement of the operating element (steering device) may/will have a smaller steering effect at high speeds.
- > The same steering movement will have a larger steering affect at low speeds.



The parameters may only be changed in authorized workshops!



Fig. 5: PARAVAN main module

7.1.2 Overview of operating elements

Individual adaptation of forces according to the requirements of the operator is achieved by an exchangeable thrust spring and an adjustable movement range for the operating elements. Fine adjustment of the system is achieved by changing the software parameters.



Mechanical/electronic parameters may only be changed by authorized workshops!



See Section "18 Your PARAVAN customer service contact"

7.2 Overview of operating elements

7.2.1 Individual modules/elements



Each of the listed, individual modules can be separately installed in the vehicle. In this case, there will only be a single PARAVAN main module in the vehicle.

List of the individual modules and their respective description (abbreviation):

Two-way accelerator/brake slider

> 2WL

Two-way accelerator/brake joystick

> 2WC

Mini-steering-wheel

> MS

Rotary steering

> RS

Two-way steering joystick

> 2WS



See Section "10 Operating the PARAVAN driving system"

7.2.2 Possible combinations of the individual modules



The PARAVAN SPACE DRIVE II driving system was designed to facilitate the combination of individual system elements according to the needs of the operator.

PARAVAN GmbH can provide the following system combinations:

Mini-steering-wheel with two-way accelerator/brake lever

> MS+2WL

Mini-steering-wheel with two-way accelerator/brake joystick

> MS+2WC

Rotary steering with two-way accelerator/brake lever

> RS+2WL

Rotary steering with two-way accelerator/brake joystick

> RS+2WC

Two-way steering joystick with two-way accelerator/brake joystick

> 2WS+2WC

Two-way steering joystick with two-way accelerator/brake lever

> 2WS+2WL

Four-way accelerator/brake and steering joystick

> 4WCS



Combinations with the four-way accelerator/brake and steering joystick (4WCS) are not offered, as all relevant functions are already considered and combined in this single module.

7.3 Orthopaedic extensions



The operating elements can be equipped with a variety of orthopaedic extensions to achieve optimal operating efficiency for the user.

PARAVAN GmbH offers suitable extensions for any type of handicap. The extensions listed represent only some of the extensions available.

Orthopaedic extensions for the mini-steering-wheel or the joystick.

- Trident
- Ball
- 2 or 3 Pin

Orthopaedic extensions for accelerator/brake slider

- T-handle
- 2 or 3 Pin
- L-handle (with sound sequence as an option)



Only orthopaedic extensions released by PARAVAN GmbH may be used!



See Section "2.2.2 Technical changes"

7.4 Overview of operating elements

7.4.1 Check control



Fig. 6: Check control

The Check Control operating element consists of a

- > 4-button operating element ①
- > Display panel ②
- > A LED for visual warning ③

that continuously provides system information for the operator.

The 4-button operating element provides an option for selecting functions and/or entering inputs into the system, e.g.

- > passwords,
- > numerical values,
- > language selection,
- > parametrisation,
- > navigation in menus.

The high-resolution VFD (Vacuum Fluorescent Display) is easy to read and automatically adjusts its intensity as soon as the low-beam light of the vehicle is switched on.

An internal CAN interface is used for communication between the Check Control and other modules, e.g. to the PARAVAN main module for factory and software updates.

7.4.2 Accelerator/brake lever and two-way joystick

The accelerator/brake slider operating element completely controls and manages the

- accelerator and brake function

based on deflection with parameter-controlled distance and force.



See Section "7.1.2 Force adjustment of the operating elements"

The two-way joystick allows setting the

- accelerator and brake function

not only in a purely mechanical way but also by parameter control that can be adjusted by software.



See Section "7.1.2 Force adjustment of the operating elements"



Fig. 7: Accelerator/brake lever



Fig. 8: Two-way joystick

7.5 General information regarding operating elements



Fig. 9: Accelerator/brake servo-motor

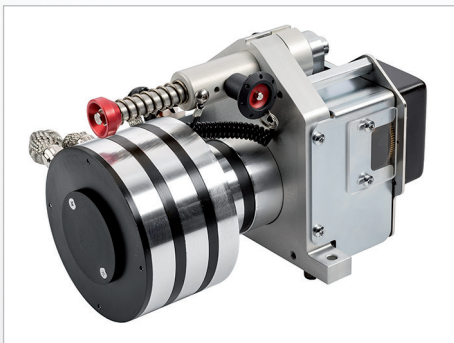

Fig. 10: Steering servo-motor



Maintenance work on control elements may only be performed by certified dealers or certified SPACE DRIVE II technicians. Maintenance and repair work may only be performed by trained persons. Never attempt to perform maintenance and repair work yourself!

Damage to the covers, servo-motors or add-on parts must generally be avoided. Careful handling of the accelerator and brake servo-motor must therefore always be ensured. These control elements must be checked by a specialist in case they show any damage.



Safety-related failure may occur when this rule is not adhered to.



See Section "14 Care and maintenance"

7.6 *Function of the operating elements*

7.6.1 Steering servo-motor

The steering function of the steering servo-motor is implemented by a modified, original steering column and a mechanical locking mechanism to the steering servo-motor.



This implies that an powered vehicle equipped by PARAVAN with a PARAVAN SPACE DRIVE II driving system can at any time also be used by non-handicapped persons.

The force connection between the steering servo-motor and the original steering column must be separated for this purposes. The separation takes place in the gearbox of the steering servo-motor by a locking mechanism ①.

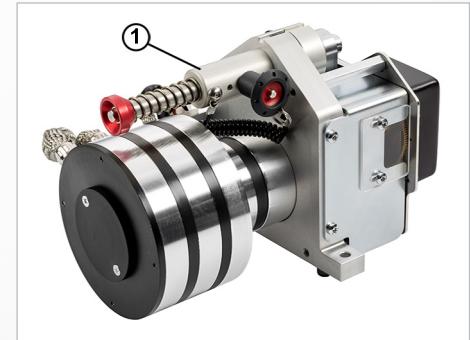

Fig. 11: Steering servo-motor

7.6.2 Accelerator and brake servo-motor

The accelerator and brake servo-motor is mounted on an attachment beam in the load-carrying structure of the vehicle.

The accelerator and brake servo-motor handles two functions:

- > A Bowden cable pulls via a deflection mechanism on the driving pedal and thus increases speed. The process is reversed to reduce driving speed.



Multiple redundancy of the systems in the vehicle ensures that the vehicle can still be controlled in the event of a fault, e.g. when a motor coil fails.

8. **Delivery of the vehicle**

8.1 **Receiving your new/altered vehicle**

Check your vehicle with PARAVAN SPACE DRIVE II driving system for completeness and compare the delivery state with the order documentation. Contact PARAVAN GmbH immediately when you have any doubt! Visually check that your vehicle is in an appropriate state. Immediately report any damage that may be due to transport or delivery in writing to your

- > dealer **and**
- > to PARAVAN GmbH.



See Section "1.1 Your manufacturer"

8.2 **The vehicle is delivered to you as follows**

The vehicle is handed to you ready to drive and in the following state:

- > Completely assembled and equipped with the PARAVAN SPACE DRIVE II driving system according to the specifications in your order.
- > All components and auxiliary elements are pre-set to your body measurements as specified in your order.

8.2.1 Settings on the vehicle

All electrical/mechanical components, equipment and operating elements are set to match your body measurements. However, if further adjustments should be necessary, they can be made at any time. Your PARAVAN SPACE DRIVE II has been designed to allow adaptation to all aspects of your body measurements and operating strength, so that optimal reach and handling of the operating elements is ensured.



For your own safety, please ensure that all mechanical settings and changes to the equipment are made by a certified service technician. Adjusting or changing the positions of system components by the customer is prohibited!



See Section "8 Vehicle delivery"



See Section " 7.1.2 Adaptation of the operating element forces"

9. Preparation of the vehicle for driving

9.1 Driving with the PARAVAN SPACE DRIVE driving system



Fig. 4: System switch

The PARAVAN SPACE DRIVE II driving system must be electrically and mechanically activated in order to make full use of it. The following work steps must be performed:

1. Switch on the driving system at the system switch (figure may differ from the original). -> The system switch must be in the "I" ON position.



The system switch may be installed in various places, depending on the vehicle type. Familiarize yourself with the installation position of the system switch.

2. Start the vehicle motor. -> The SPACE DRIVE driving system is in the start-up phase (booting). -> Follow the instructions on the Check Control display.



The PARAVAN SPACE DRIVE driving system will check the position or the presence of the locking pin. If this is not detected, the locking pin must be correctly inserted and the following message will be shown on the Check Control display:

> Electrical steering not locked!!! Drive without?

 See Section "9.1.1 Correct position of the locking pin"

When this message does not appear, the locking pin and its position have been recognized and your vehicle is ready for use with the PARAVAN SPACE DRIVE driving system.

3. Starting the driving system.

 See Section "10 Operating the PARAVAN driving system"

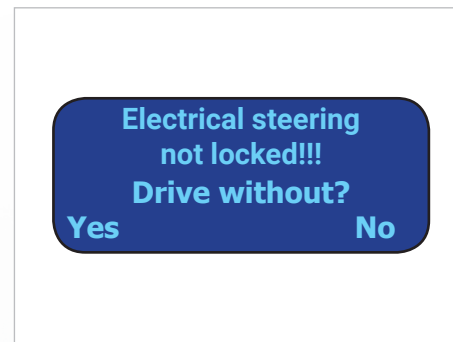

Fig. 5: Steering not switched on



Fig. 6: Check Control display

9.1.1 Put the locking pin in the correct position

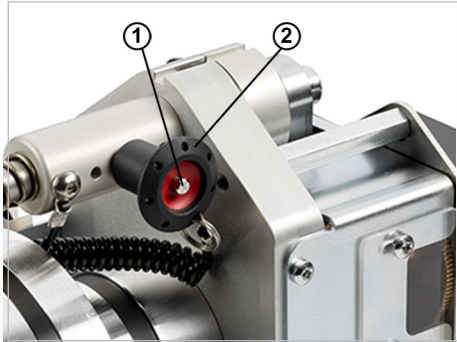

Fig. 7: Locking pin position

1. Remove the locking pin from the steering servo-motor. -> Press and hold the internal button ① of the locking pin. -> Pull out the ② locking pin.

2. Perform the "Align steering and steering servo-motor" work steps.



See Section "9.1.2 Align steering and steering servo-motor"

3. Connect and latch steering column and steering servo-motor. -> Press and hold the ③ locking pin. -> Push the unlocking bolt ④ forwards. -> Release the ③ locking pin.

 The unlocking bolt ④ is spring-loaded and automatically pushes back to the initial position!

 The locking pin ③ must latch automatically. Only this will ensure that the steering servo-motor and the steering column are mechanically linked to each other in an appropriate way!

4. Position control of the locking pin. -> Move the vehicle steering wheel with little deflection to the "left/right".

 Check for free movement of the running wheels! Avoid contact with the kerb!

5. Insert the locking pin. -> Keep pressing the inner button of the ② locking pin. -> Insert the locking pin. -> Release the button of the ② locking pin.

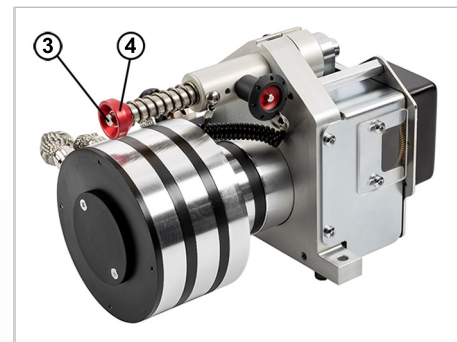

Fig. 8: Locking pin

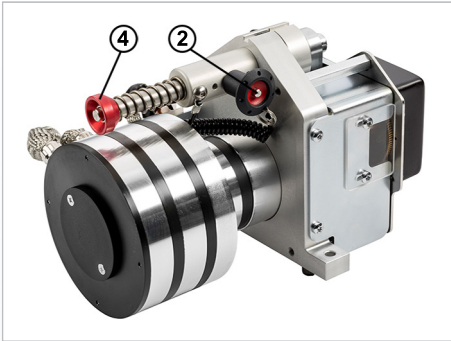

Fig. 9: Locking pin



The inner button must automatically latch!

6. Check that the locking pin has latched -> Change the position of the locking pin ④ as required.



Driving without the locking pin is prohibited!



See Section "10 Operating the PARAVAN driving system"

9.1.2 Align the steering and the steering servo-motor



The following message will be shown on the Check Control display:

> Electrical steering not locked!!! Drive without? Yes / No

The position of the vehicle steering and the position of the steering servo-motor do not correspond. The steering servo-motor cannot be latched to the steering of the vehicle. Align the vehicle steering and the steering servo-motor by performing the following work steps:

1. Turn the running wheels of the vehicle to point straight forward



Check for free movement of the running wheels! Avoid contact with the curb!

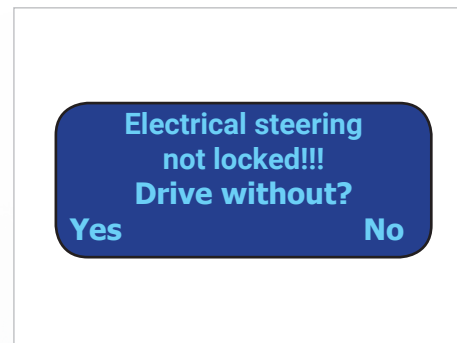

Fig. 10: Steering not switched on

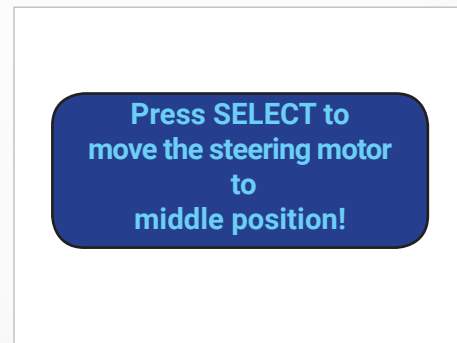

Fig. 11: Middle position, move



Fig. 12: Latch steering



Fig. 13: Start motor



The PARAVAN SPACE DRIVE II driving system (steering servomotor) will automatically and independently move to the middle steering position.

After successful alignment or when the driving system has reached the middle position or when it is already in this position, the display of the Check Control operating element will show:

> Please latch the steering and confirm with SELECT!

2. Start the vehicle motor.

3. Align the steering -> Execute deflection (left/right) of the running wheels using the steering operating element.

After successful alignment or when the PARAVAN SPACE DRIVE II driving system has reached the middle position or when it is already in this position, the display of the Check Control operating element will show the start screen.

 The vehicle steering and the PARAVAN SPACE DRIVE II driving system are now calibrated to match each other.

4. Check the position of mechanical safety systems -> Check the unlocking bolt ④ and the locking ② pin.

 Driving when the locking pin is not latched ② is prohibited!

 See Section "10 Operating the PARAVAN driving system"



Fig. 14: Start screen

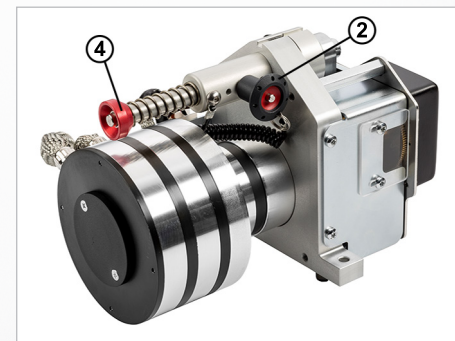

Fig. 15: Fuses, mechanical

9.2 Driving without the PARAVAN SPACE DRIVE driving system



Fig. 16: System switch

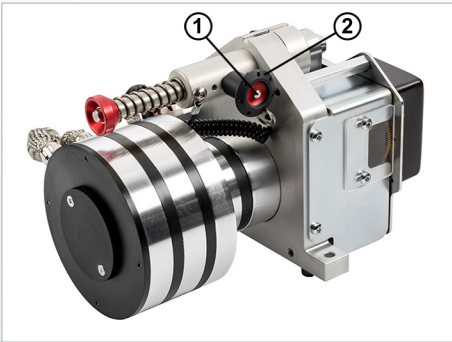

Fig. 17: Locking pin



There are some situations in which it is necessary to switch off the PARAVAN SPACE DRIVE II driving system.

The PARAVAN SPACE DRIVE II driving system must be electrically and mechanically deactivated. The following work steps must be performed:



Check for free movement of the running wheels! Avoid contact with the curb!

1. Turn the running wheels to point straight forward.
2. Select driving mode "P".
3. Switch off the driving system at the system switch. -> The system switch must be in the "O" OFF position.



The system switch may be installed in various places, depending on the vehicle type.

4. Remove the locking pin from the steering servo-motor. -> Press and hold the ① the inner button. -> Pull out the ② locking pin.

5. Separate the link between steering servo-motor and steering column. -> Press and hold the ③ locking pin. -> Push the unlocking bolt ④ downwards. -> Release the ③ locking pin.

i The locking pin must automatically latch!

6. Insert the locking pin into the steering servo-motor -> Keep pressing the inner button of the ① locking pin. -> Insert the ② locking pin. -> Release the inner button of the ① locking pin.

i The inner button must automatically latch!

7. Check that the locking pin has latched. -> Change the position of the locking pin as required.

i Driving without the locking pin is prohibited!

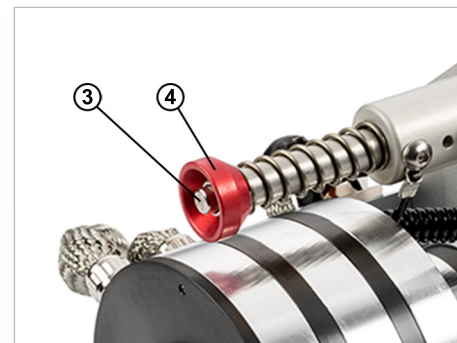

Fig. 18: Unlocking bolt

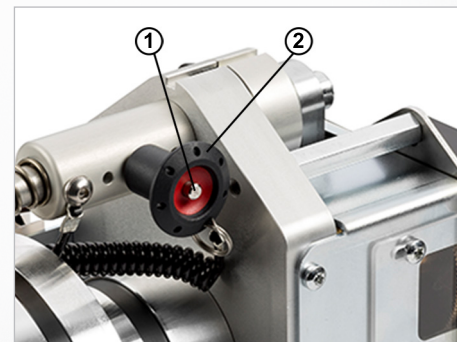

Fig. 19: Locking pin

9.3 Insurance, personal liability insurance

We recommend to contact your insurance advisor before starting to use the vehicle, so that the use of the vehicle can be included in your insurance policies – in particular in your personal liability insurance.



Please note that the vehicle may have to be insured in order to use it in public road traffic according to local legislation.



WARNING

Risk of personal injury when operating the vehicle in a state that does not conform to the original or delivery state.

Damage to the vehicle due to non-authorized or incorrectly installed components.

- > Do not make any technical changes to the vehicle.
- > Use only original or authorized replacement parts.
- > The operating condition of the vehicle should be checked before each drive.

9.4 *Functional checking before driving*

For your own safety, you must check the following points before each drive.

- > Start and stop function (brakes) of the vehicle.
- > Function of the lighting system of the vehicle.



You may need to involve a second person for such a check.



See "User's Manual" of the vehicle manufacturer.

- > Fitting the safety belt.



Listen for an audible click of the buckle latch in the belt fastener when fastening the safety belt.

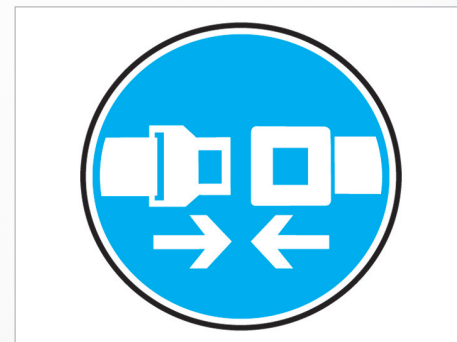

Fig. 20: Fasten seat belt, logo

10. Operating the PARAVAN driving system

10.1 Starting the driving system, sequence of steps

10.1.1 Before starting the motor

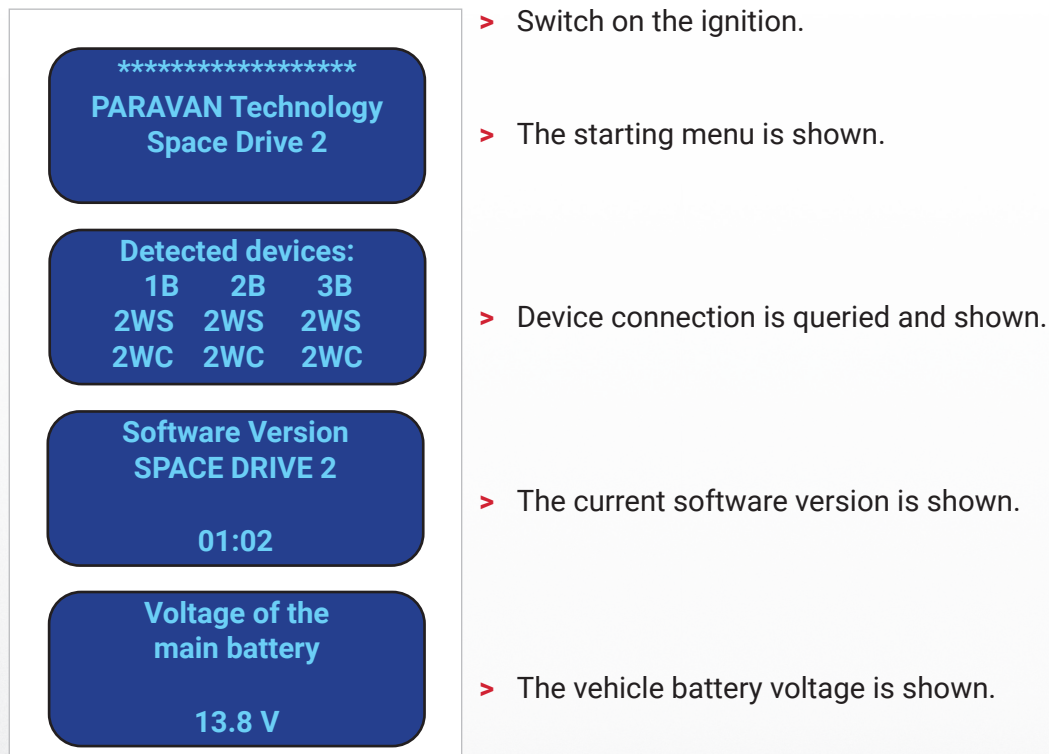

Fig. 11: Sequence of steps

- > The voltage of the secondary (backup) battery is shown.

- > Request to start the vehicle motor.



Start the vehicle motor. -> Vehicle motor is running.

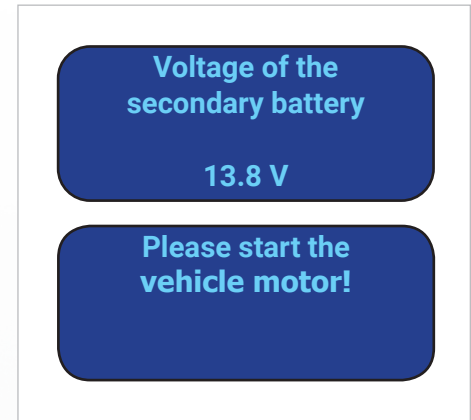
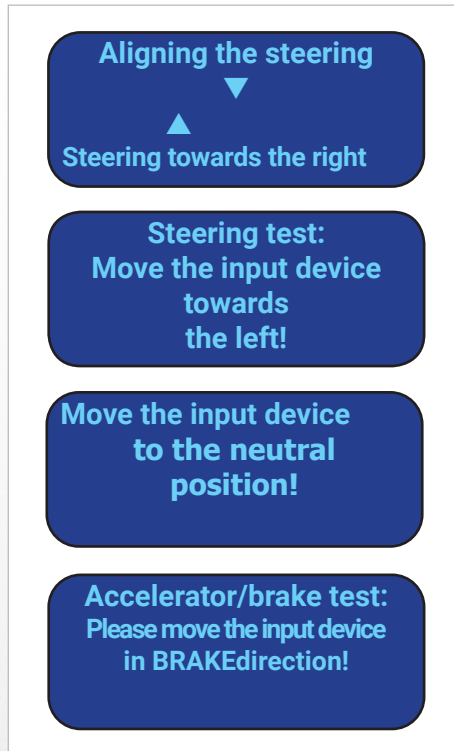

Fig. 12: Sequence of steps

10.1.2 After starting the motor



-> Vehicle motor is running.

- > Align the steering, follow the instructions.
- > Steering test, follow the instructions.
- > Bring input device into neutral position.
- > Accelerator/brake test, follow the instructions.

Fig. 13: Sequence of steps

> System start of the driving system completed.



The vehicle with the PARAVAN driving system is ready to drive.

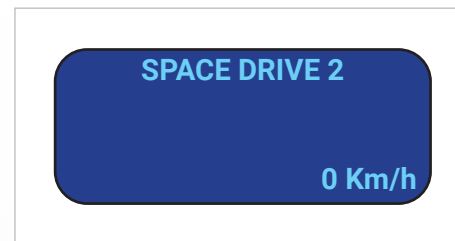

Fig. 14: Sequence of steps

10.2 *Operating the accelerator and brake function*

10.2.1 Accelerator/brake joystick (2-way)



Fig. 15: Accelerator/brake joystick



The accelerator and brake joystick operating element directly controls the accelerator and brake actuator motor. The movement of the joystick is converted to an accelerator or brake signal that is executed by the respective accelerator/brake motor.

Move the joystick in the desired direction:

- > The vehicle will execute the command. ☒ Braking; the vehicle reduces driving speed and might finally come a standstill. ☒ Accelerating; the vehicle drives or picks up speed.



See Section "7.1.2 Force adjustment of the operating elements"

10.2.2 Accelerator/brake lever (2-way)



The accelerator/ brake slider operating element directly controls the accelerator and braking actuator motor. The movement of the accelerator/brake slider towards the accelerator or brake signal is implemented by the respective accelerator/brake motor.

Slide the accelerator/brake slider in the desired direction:

- > The vehicle will execute the command. ☒ Braking; the vehicle reduces driving speed and might finally come a standstill. ☒ Accelerating; the vehicle drives or picks up speed.



See Section "7.1.2 Force adjustment of the operating elements"



Fig. 16: Accelerator/brake lever

10.3 Operating the steering function

10.3.1 Mini-steering-wheel



Fig. 17: Mini-steering-wheel



The mini-steering-wheel has a diameter of approx. 120 mm and allows for very comfortable operation of the vehicle. The movement of the mini-steering-wheel is converted to a steering signal and executed by the steering actuator motor.

The operation and function is modelled on an original vehicle steering wheel:

- > ↻ Rotary movement to the right (right bend). -> Running wheels turn to the right.
- > ↻ Rotary movement towards the left (left bend). -> Running wheels turn to the left.



See Section "7.1.2 Force adjustment of the operating elements"

The mini-steering-wheel may be equipped with a variety of different orthopaedic extensions, depending on the level and the type of disability, e.g.:

- > Ball
- > Cone
- > Cylinder, etc.



See Section "7.3 Orthopaedic extensions"

10.3.2 Steering joystick (2-way)



The steering joystick directly controls the steering actuator motor. The movement of the joystick is converted to a steering signal and executed by the steering actuator motor.

Move the joystick in the desired direction:

- > The vehicle will execute the command. ① The running wheels turn to the right, follow a right bend. ② The running wheels turn to the left, drive a left bend.



See Section "7.1.2 Force adjustment of the operating elements"



Fig. 18: Steering joystick

10.3.3 Rotational steering unit



Fig. 19: Rotational steering unit



The rotational steering unit makes driving the vehicle very comfortable. The movement of the rotational steering unit is converted to a steering signal and executed by the steering actuator motor.

Move the joystick in the desired direction:

- > Swiveling movement to the right (right bend). -> Running wheels turn to the right.
- > Swiveling movement towards the left (left bend). -> Running wheels turn to the left.



See Section "7.1.2 Force adjustment of the operating elements"

10.4 Operating the accelerator/brake function and the steering function

10.4.1 Accelerator/brake and steering joystick (4-way)



Fig. 20: 4-way joystick



The accelerator/brake and steering joystick operating element separately controls the respective actuator motors. The movements of the joystick are converted into steering signals on the one hand and into accelerator and brake signals on the other hand.

Move the joystick in the desired direction:

- > The vehicle will execute the command. ① Braking, the vehicle reduces driving speed and might finally come a standstill. ② The running wheels turn to the right, follow a right bend. ③ Accelerating; the vehicle drives or picks up speed. ④ The running wheels turn to the left, drive a left bend.



See Section "7.1.2 Force adjustment of the operating elements"



To prevent the wheelchair from moving in an undesirable way, do not provide any sudden drive commands when using the joystick!

11. Operating the Check Control

11.1 Navigation in the menu structure





Fig. 21: Operating panel Check Control



The Check Control is the communication element for the driving system. Operator and service technicians can use the **SEL** push buttons to call up the basic information of the driving system after the system has been started.

Operating panel of the Check Control:

- >  ①
Scroll backwards in the menu or change parameter (smaller).
- >  ②
Scroll forwards in the menu or change parameter (larger).
- > **SEL.** ③
 - > The menu entry shown on the display is selected.
 - > The function of the displayed menu entry is executed.
 - > Input into Check Control is confirmed/stored.
- > **ESC.** ④
 - > Leave the menu selected.
 - > Jump back to the previous menu.



See Section "11.1.1 Menu structure Check Control"

11.1.1 Menu structure of the Check Control



After pressing the **SEL** push button, the start menu (customer menu) is shown. It is now possible to select 6 further menus by pressing the ◀/▶ push buttons.

The menu structure is arranged in a clockwise sequence as follows:

- > Battery voltages
- > Fine-calibration of the steering
- > Software version
- > Maintenance intervals
- > Date and clock
- > Button illumination

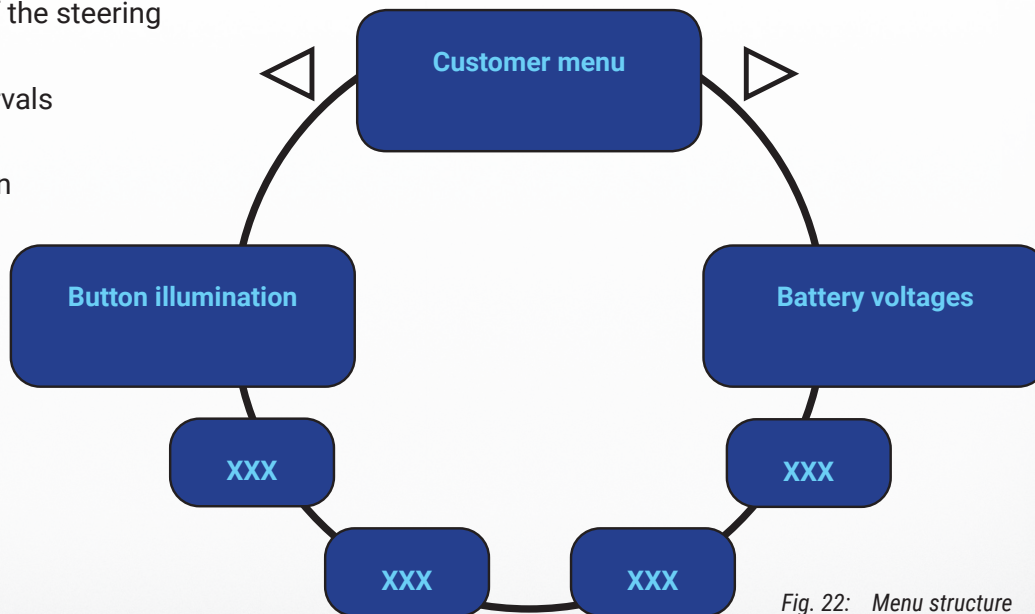

Fig. 22: Menu structure

12. Customer menu

12.1 Battery voltages

General

Information

Prepare

Operate

Help

Technology

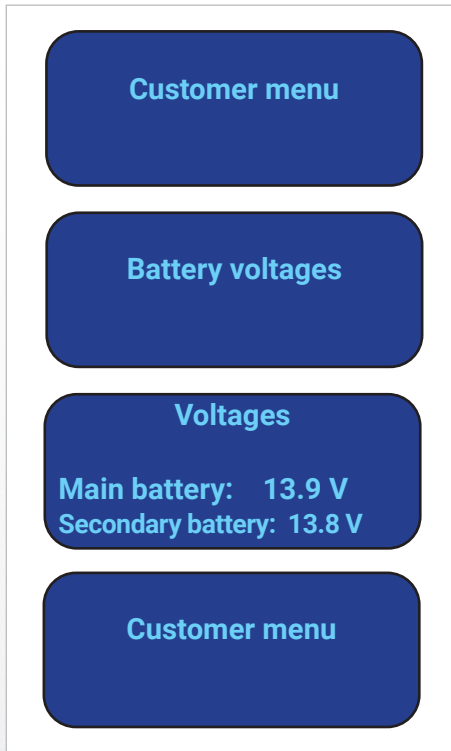

> The customer menu is shown.

Continue with **SEL**.

> The "battery voltages" menu screen is shown.

Continue with **SEL**.

> The battery voltages are shown.

Continue with **ESC**.

> The "customer menu" screen (=Starting screen) is shown.

Fig. 23: Sequence of steps

12.2 *Fine-calibration of the steering*

Continue with **▶**

- > The "fine calibration steering" menu screen is shown.

Continue with **SEL.**

- > The "L-fine-calibration" menu screen is shown.

- > The L-fine-calibration menu screen is shown on the left or right side.

Change the value with **◀** or **▶**

Continue with **ESC.**

- > The value will automatically be stored after the change.
- > Jump back to the previous menu.

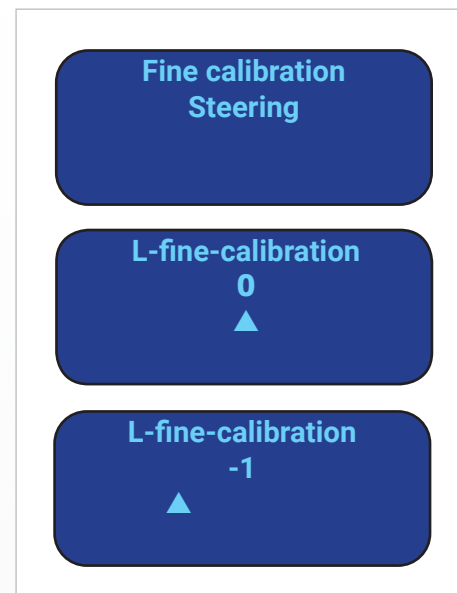

Fig. 24: *Fine calibration*

12.3 Software version



Fig. 25: Software version

Continue with **▶**

- > The "software version" menu screen is shown.

Continue with **SEL**.

- > The current software version is shown.

Continue with **ESC**.

- > Jump back to the previous menu.

12.4 Maintenance intervals

Continue with **▶**

- > The "maintenance interval" menu screen is shown.

Continue with **SEL**.

- > Remaining time of maintenance interval is shown.

Continue with **ESC**.

- > Jump back to the previous menu.

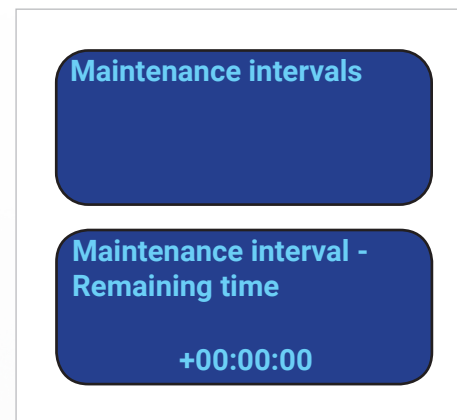

Fig. 26: Maintenance intervals

12.5 Date and clock

General

Information

Prepare

Operate

Help

Technology

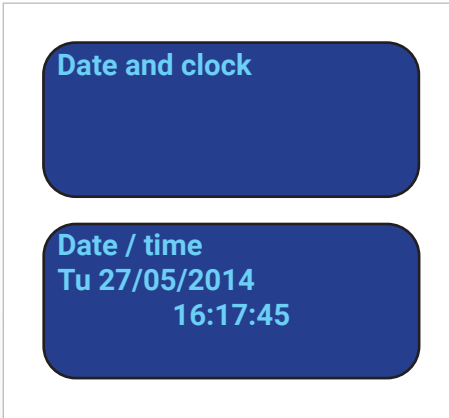

Fig. 27: Date / time

Continue with **▶**

> The "date and time" menu screen is shown.

Continue with **SEL**.

> The current date and the time are shown.

Continue with **ESC**.

> Jump back to the previous menu.

12.6 *Button illumination, color*

Continue with **▶**

- The "button illumination" menu screen is shown.

Continue with **SEL**.

- The "button illumination colour" menu screen is shown.

Continue with **SEL**.

- The "button illumination colour: cyan" menu screen is shown. Select further colors (yellow, white, red, green, blue, purple) as required using **▶**.

Continue with **ESC**.

- The value will automatically be stored after the change.
- Jump back to the previous menu.

Customer menu

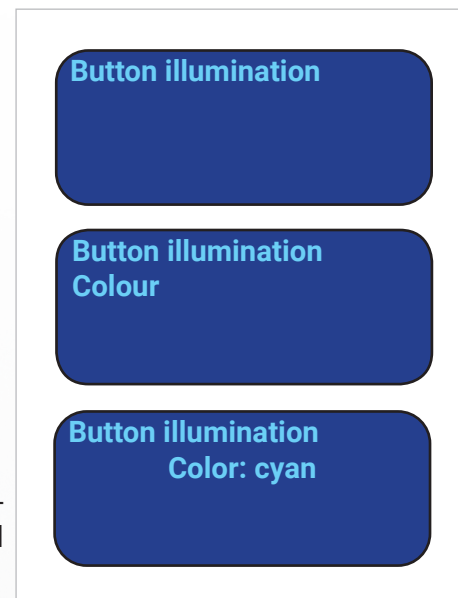

Fig. 28: *Button illumination*

12.7 *Button illumination, day*

General

Information

Prepare

Operate

Help

Technology

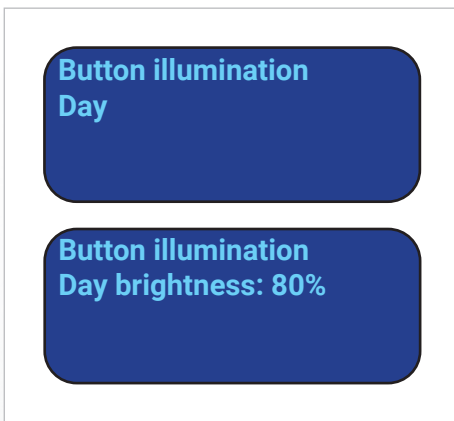

Fig. 29: *Button illumination*

Continue with **▷**

- > The "button illumination, day" menu screen is shown.

Continue with **SEL**.

- > The "button illumination, day brightness" menu screen is shown.

Change the value with **◀** or **▶**

Continue with **ESC**.

- > The value will automatically be stored after the change.
- > Jump back to the previous menu.

12.8 *Button illumination night*

Continue with **▶**

- > The "button illumination, night" menu screen is shown.

Continue with **SEL**.

- > The "button illumination, night brightness" menu screen is shown.

Change the value with **◀** or **▶**

Continue with **ESC**.

- > The value will automatically be stored after the change.
- > Jump back to the previous menu.

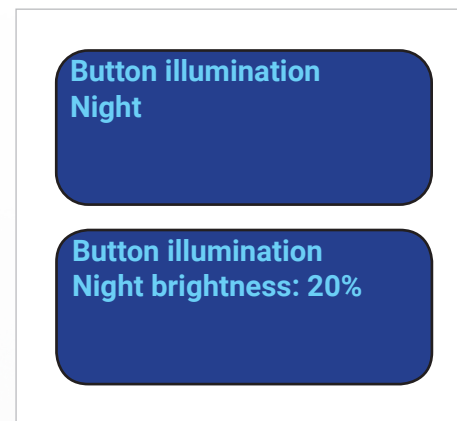

Fig. 30: *Button illumination*

13. **Loading and transporting your vehicle**

General

Use a professional breakdown service in the event that your vehicle breaks down and has to be loaded onto a car transport trailer.

Information

The loading and securing of the vehicle is described in the User's Manual of the vehicle. Possible securing points, e.g. towing hooks, are also described there.

Prepare

Your vehicle has to be secured on a loading platform according to the Road Traffic Licensing Ordinance, specifically:

- VDI Directive 2700 Sheet 8: "Securing road vehicles loaded onto car transporters"

Operate

Support the breakdown service:

- Hand the User's Manual of the vehicle manufacturer to the breakdown service.
- Hand this User's Manual to the breakdown service.
- Support the breakdown service with instructions regarding the operation of your vehicle, e.g. activate the parking brake or interrupt the ignition current (ignition off).

Help

Technology



See "User's Manual" of the vehicle manufacturer.

Appropriate use and operation of your vehicle with the PARAVAN SPACE DRIVE II driving system is subject to the vehicle-independent maintenance plan for the PARAVAN SPACE DRIVE II driving system. All powered parts, particularly the actuator motors, are designed for low-maintenance, fault-free operation.

However, the following issues must be considered to ensure flawless operation of the PARAVAN SPACE DRIVE II driving system:

- > It should be handled with care
- > It should be kept clean
- > It should be maintained according to the maintenance plan.



The earliest deadlines in the maintenance plan apply. This includes regular intervals in years (time) and specific performance parameters (operating hours).



See "Maintenance instructions"

Please get in touch with your certified dealer or contact PARAVAN GmbH directly in case you have any questions.



See Section "18 Your PARAVAN customer service contact"



DANGER!

Mortal danger for persons driving a vehicle with a SPACE DRIVE system when the vehicle and the SPACE DRIVE system are not subject to regular inspection.

Mortal danger for all persons who lose control of their vehicle due to inappropriately performed maintenance, inspection or repair work.

Damage to the vehicle and the SPACE DRIVE system when the inspection and repair work is not performed by authorized service technicians or maintenance personnel.

- > Perform maintenance and inspection work according to the maintenance plan.
- > Maintenance, inspection or repair work on the driving system may only be performed by certified service technicians or maintenance personnel.
- > Maintenance and inspection intervals must always be adhered to.

14.1 *Cleaning and care*



No running water may be used for cleaning the modules (input devices and operating elements). Ensure that electronic parts cannot come into contact with water.

Only use mild soaps solutions without abrasive additives

> to clean the module frame or the plastic

components.

Only conventional

> surface disinfectants and

> damp micro-fibre cloths,

should be used to disinfect operating elements.

15. *Disposal and environmental protection*

General

Information

Prepare

Operate

Help

Technology

The PARAVAN SPACE DRIVE II driving system and its individual components have a long service life. During manufacture and construction, care was taken to use recyclable and harmless raw materials as much as possible. The PARAVAN SPACE DRIVE II driving system can be removed and recycled or disposed of in an environmentally compatible manner when the vehicle is no longer used.



National and regional regulations on the disposal of waste must be followed.

The PARAVAN SPACE DRIVE II driving system can be disassembled into the following components for recycling:

- Metals
- Plastics and composite materials
- Electronic waste
- Accumulators.

An effort should be made to achieve a high level of recycling appropriate to the type and nature of the waste material (according to the German Life-Cycle Management of Waste Materials Act). The recycling process is considered economically feasible if the costs associated with the process are not out of proportion to the costs that would be incurred by disposal of the waste.

15.1 Packaging materials

The packaging is largely made of recyclable and environmentally harmless materials, such as:

- > Bubble wrap,
- > cardboard.



Take advantage of the opportunity to recycle the packaging in an environmentally friendly manner. Recycling of waste is preferable to disposing of it.

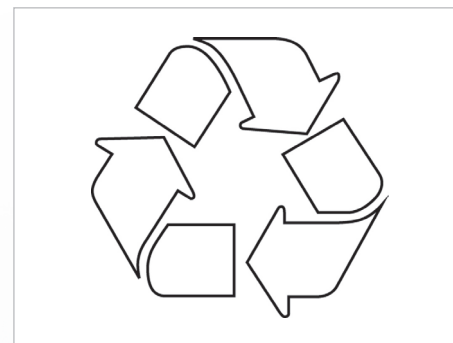

Fig. 16: Recycling

15.2 Re-commissioning

The following work steps have to be performed before re-operation when a vehicle with a PARAVAN SPACE DRIVE II driving system was not used for a prolonged period:

- > Check all safety devices and repair them where necessary
- > Undertake a complete service and revision
- > System check, software update as required.



The PARAVAN SPACE DRIVE II driving system must be completely serviced and released for use after thorough inspection by a service technician authorized by PARAVAN GmbH.



See "Maintenance instructions"

15.3 *Notes on transferring the vehicle*

All technical documentation required for safe handling and operation must be forwarded to the new owner when a vehicle with a PARAVAN SPACE DRIVE II driving system is transferred, e.g. sold. This includes:

- > The User's Manual and
- > service logs.



See "Maintenance instructions"

16. **Correcting failures**

16.1 **Initial steps, fault search**



Stop the vehicle without haste and in a place where it does not pose a traffic hazard if your PARAVAN SPACE DRIVE II driving system shows an error or fault. Do not stop the vehicle in a tunnel, on a railway crossing or in places with bad visibility.

1. Secure the vehicle against unintentional movement, e.g. automatic gearbox in parking position (driving position P) or activate the parking brake (manual brake).
2. Restart the system (boot) the PARAVAN SPACE DRIVE II driving system.



See Section "10 Operating the PARAVAN driving system"

3. Secure the vehicle, check the drive system and exchange faulty fuses as required.



See "User's Manual" of the vehicle manufacturer.

16.2 *Fault message*



Please visit a workshop when the text "Critical fault" is shown on the Check Control display. It is generally permitted to drive on when the warning goes off.

When the fault message appears frequently or is shown permanently,

- > visit a workshop **and**
- > contact PARAVAN.



See Section "18 Your PARAVAN customer service contact"

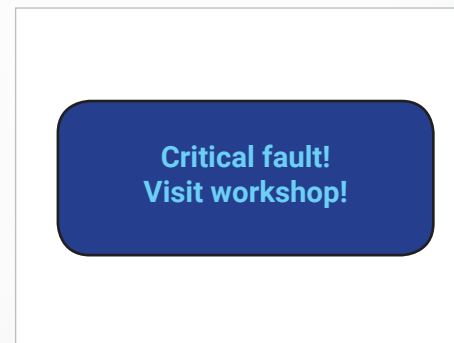

Fig. 17: Critical fault!

17. **Emergency mode**

General

Information

Prepare

Operate

Help

Technology



For safety reasons, operation is only possible with limited speed when the vehicle is in emergency mode.



WARNING

Risk of injury for persons who operate the vehicle in emergency mode after the failure of power support systems e.g. steering pump, servo-pump.

Damage to the vehicle in emergency mode due to failure of power support systems, e.g. steering pump, servo-pump.

- > Increased steering and braking effort will be necessary. Drive proactively and with particular care.
- > Restore the appropriate operating state of the vehicle and the driving system.
- > Use only original or authorized replacement parts.
- > Visit a workshop or service station and have the fault removed.

17.1 Accident



Do not use the vehicle before a maintenance inspection at a workshop when a vehicle with a PARAVAN SPACE DRIVE II driving system is involved in a traffic accident. The vehicle or components of the system may be damaged in a way that is not visible but may nevertheless lead to malfunction.



See Section "18 Your PARAVAN customer service contact"



DANGER!

Mortal danger for persons who operate a vehicle with driving system after an accident.

Mortal danger for persons who lose control of their vehicle due to malfunctions resulting from faulty system components.

- > Do not drive a vehicle after an accident.
- > Immediately have the vehicle and all system components serviced by an authorized service technician.
- > Immediately inform PARAVAN GmbH.

18. **Your contact to the PARAVAN customer service**

18.1 **Hotline**



Your Space Drive dealer will gladly help you with repairs or spare parts procurement for your PARAVAN vehicle system.

General

Information

Prepare

Operate

Help

Technology

19. **Electrical system**

19.1 **Notes on the power supply**

The PARAVAN SPACE DRIVE II driving system is equipped with a powerful, high-quality battery. This maintenance-free battery is completely sealed. The system is not designed to need or allow any refilling or topping up of the electrolyte (battery acid).



The charging status and capacity of the battery and internal vehicle battery are indicated in the customer menu during the booting process.



Avoid voltage peaks! Quickly remove the terminal clamps when exchanging or disconnecting the vehicle battery.

19.1.1 Starting the vehicle with external power

Once the on-board voltage of the vehicle has dropped so far that it can only be started with external power, e.g. from a second vehicle, the vehicle must be connected or linked up according to the information of the vehicle manufacturer.



See "User's Manual" of the vehicle manufacturer.



Avoid voltages above +15 Volt!

19.2 Charge the batteries



The voltage is monitored and independent charging may take place once the motor has been started. Manual charging of the batteries (vehicle and backup battery) is not necessary when you regularly operate your vehicle.

It is recommended to connect the vehicle to a commercial battery charger, e.g. overnight, when the vehicle is rarely operated or when a prolonged standstill period is foreseen.

Perform the following work steps:

1. Ignition current off (ignition off).
2. Connect the vehicle and the battery charger according to manufacturer information.



See Section "19.3.1 Maintenance charge of backup battery"

3. Start charging process.

19.3 Notes on maintenance charge



Sealed batteries should never be opened. Opening the batteries will cause irreparable damage to these components, possibly resulting in a complete failure of the power supply.



See Section "21.1 Dealing with sealed batteries"



Always connect your vehicle to the charger when it is not used for a prolonged period! Commercial chargers automatically switch to "Maintenance charge" and thus ensure a continuously operational and fully charged battery in the vehicle and the driving system. Batteries will become deeply discharged and will no longer be capable of recharging and/or will need to be replaced when they are not charged for a long time.



Observe the relevant regulations on waste disposal when disposing of the batteries.



See Section "15 Disposal and environmental protection"



Fig. 17: Backup battery

19.3.1 Maintenance charge



Fig. 18: Button for external charging

i The backup battery must be fully charged after approximately 1 year without driving according to the specifications of the manufacturer.

i The external loading function must be activated/deactivated with the ① button while the ignition switched off.

1. Connect the vehicle to the charger
2. Press the ① button -> LED ② in the button lights up -> The charging process is active

> After charging, e.g. overnight

3. Press the ① button -> LED ② in the button goes off -> The charging process is completed

or

4. Switch on the ignition current (ignition on) -> LED in the button goes off -> The charging process is completed

20. *Technical equipment*

20.1 *Technical data*

| Operating specifications | |
|---------------------------------|--|
| Operating temperature | -40°C to +85°C |
| Storage temperature | -40°C to +125°C |
| Operating voltage 12 Volt | +10.5V DC to +15V DC |
| Current draw, typically | approximately 7A per module |
| Max. current draw | 35 A per module (limited current draw) |
| Cycle time | 10 ms |

General

Information

Prepare

Operate

Help

Technology

20.2 Replacement parts



The replacement of original parts by third-party components or by reproduction (copied) original parts is strictly forbidden! Obtain all your spare parts from your dealer or from PARAVAN GmbH.



See Section "1.1 Your manufacturer"

| |
|---|
|  <h3 style="margin: 0;">WARNING</h3> |
| <p>Risk of personal injury when operating the vehicle with a driving system that does not correspond to the original or delivery state.</p> <p>Physical damage to the vehicle or the SPACE DRIVE system due to non-authorized or incorrectly installed components.</p> <ul style="list-style-type: none"> > Do not make any technical changes to your SPACE DRIVE system. > Only operate your driving system in its original or delivery state. > Use only original or authorized replacement parts. > Check the operating state of the driving system before each drive. |

21. ***Systems and technical documentation***

21.1 ***Handling the sealed backup battery***

The backup battery of the PARAVAN SPACE DRIVE II driving system is a lithium-ion battery that is charged by the vehicle while driving, using internal load regulation.

The lithium-ion battery is maintenance-free.



The battery must be exchanged when it heats up or shows traces of burning or damage to the battery housing. Please contact your specialised dealer.



See Section "18 Your PARAVAN customer service contact"

21.2 Certification for lithium battery

21.2.1 Copy of the certificate



**CERTIFICATION
FOR LITHIUM BATTERY**

TRANSPORTATION CERTIFICATE

Concerning the transport according to the dangerous goods regulations of the different transport modes as in force since January, 1st 2003 and changes effective from 2013

WE HEREWITH CERTIFY THAT EACH BATTERY PACK IS OF THE TYPE PROVED TO MEET THE REQUIREMENTS OF EACH APPLICABLE TEST IN THE UN MANUAL OF TESTS AND CRITERIA, PART III, SUB-SECTION 38.3, REV. 5, AMEND. 1

| | |
|--|--|
| CERTIFICATE/REPORT NO.: BU-2014-000664-UN | |
| UN No. / Shipping name: | UN 3480 LITHIUM ION BATTERY UN 3481 LITHIUM ION BATTERY packed with equipment / contained in equipment |
| Certified Product: | LITHIUM ION BATTERY (rechargeable) |
| Model Designation: | 4S16P APR18650M1 (13.2V/17.6Ah) |
| Article Number: | 22065 |
| Certificate Holder: | Paravan GmbH Paravan Str. 5-10 · D-72539 Pfundstetten Achelau · Germany |

| PERFORMED TESTS | RESULTS |
|---|----------------|
| 38.3.4.1 Test 1: Altitude Simulation | passed |
| 38.3.4.2 Test 2: Thermal Test | passed |
| 38.3.4.3 Test 3: Vibration | passed |
| 38.3.4.4 Test 4: Shock | passed |
| 38.3.4.5 Test 5: External Short Circuit | passed |
| 38.3.4.6 Test 6: Impact/Crush | not applicable |
| 38.3.4.7 Test 7: Overcharge | passed |
| 38.3.4.8 Test 8: Forced Discharge | not applicable |

▶ Watt-hour rating of the battery pack: 232.32 Wh4

As the Watt-hour rating of the battery pack is more than 100 Wh, this lithium ion battery pack has to be declared and shipped as **DANGEROUS GOODS -Class 9-** According to Packing Instruction 905 (UN 3480) or 906/907 (UN 3481), Section 1 – Fully Regulated Class 9 Lithium Ion Cells and Batteries - of the IATA-DCR and Packing Instruction 9003 of the ADR and IMDG Code. ▶ THE "DANGEROUS GOODS" LABEL "CLASS 9" IS REQUIRED4





**www.battery
university.eu**
battery@university.eu GmbH
AHL-STRASSE 30 · 83714 KACHING (MÜNCHEN)
Tel. +49(0)188 99 410 0 · Fax 99 410 20
mailto:university@university.eu · www.batteryuniversity.eu

16-Apr-2014
Date of issue

Signature: Sven Bauer, CEO

The regulation listed here reflects the status at the time of the release of this certificate.

Fig. 19: Certification for lithium battery



PARAVAN SPACE DRIVE SYSTEM

User Manual
PRIMARY FUNCTIONS

ORIGINAL MANUAL



Paravan GmbH

Paravanstraße 5-10
72539 Pfronstetten-Aichelau
Deutschland

Telefon: +49 (0) 73 88 / 99 95-60
Fax: +49 (0) 73 88 / 99 95-999
Email: info@paravan.de

www.paravan.com